







-  Canalette e tubazioni esistenti
-  Nuova canaletta di raccolta delle acque meteoriche
-  Pozzetti in calcestruzzo
-  Tubazione sottopasso strada
-  Allineamento di embrici
-  Contorno dell'area di intervento
-  Quote finali a copertura completa



- Spessore mm 2,7  
(30 kg/ml compreso  
angolare e bulloneria)
- 1 canaletta
  - 2 supporto
  - 3 piede
  - 4 staffa

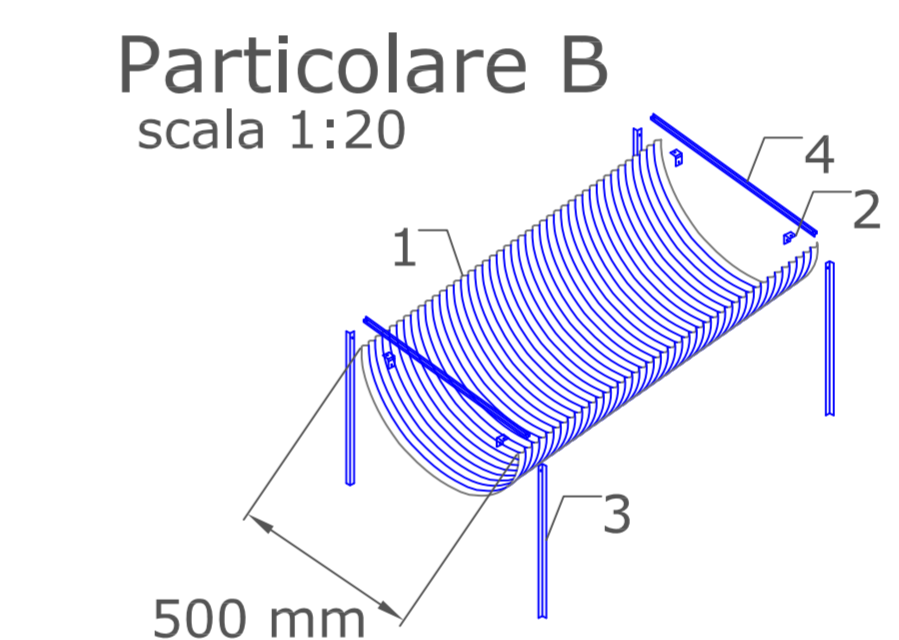
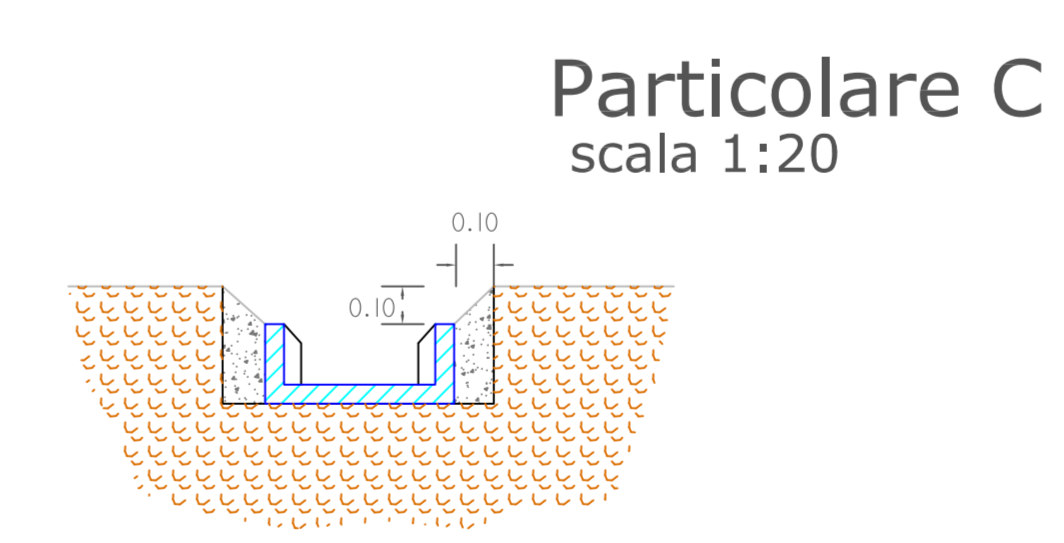

**Planimetria**  
scala 1:500

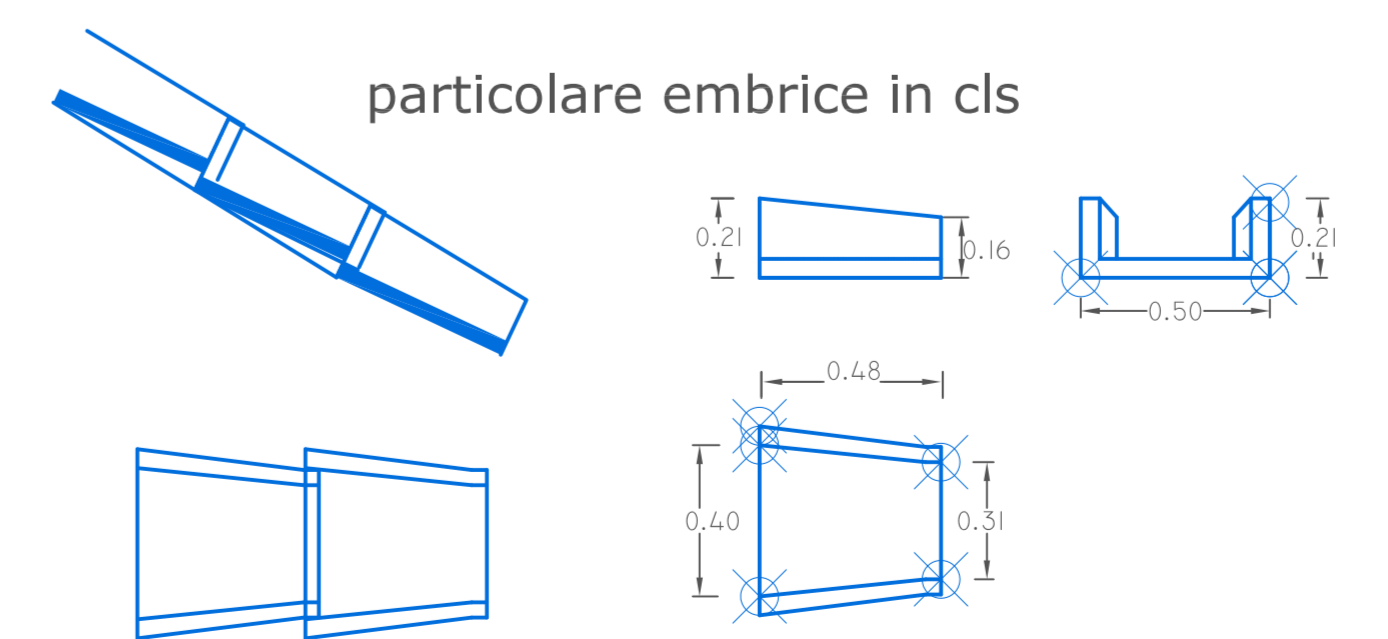
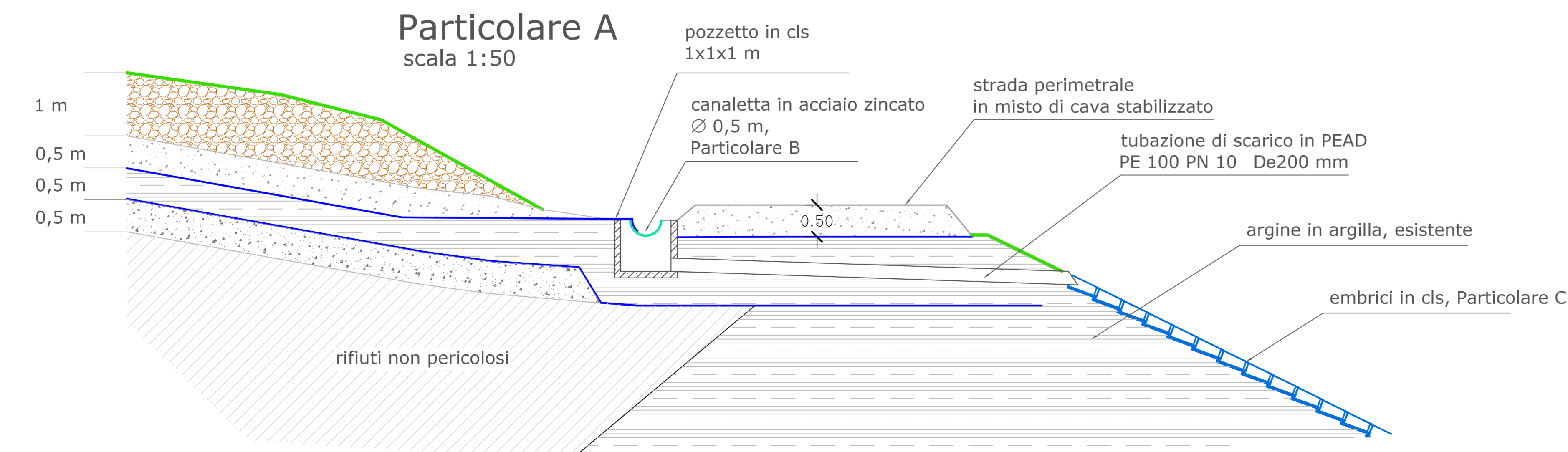

Regione Piemonte  
**ASRT**  
SOCIETA' PUBBLICA PER IL RECUPERO  
ED IL TRATTAMENTO DEI RIFIUTI  
Strada vecchia per Bosco Marengo - Novi Ligure  
Provincia di Alessandria

POTENZIAMENTO DISCARICA CONTROLLATA  
PER RIFIUTI SOLIDI NON PERICOLOSI  
IN NOVI LIGURE  
Sistemazione finale comparti 4.1 e 4.2

Progetto esecutivo

GRUPPO DI LAVORO:

|      |       |            |              |                |
|------|-------|------------|--------------|----------------|
| Rev. | Data  | REDAZIONE  | APPROVAZIONE | AUTORIZZAZIONE |
| 00   | 06/11 | N. Buglisi | A. Bacci     | F. Borgni      |

Elab. n. D.3  
Scala varie  
Data giugno 2011  
File n. 11508